

RACAL INSTRUMENTS
1260-114
HIGH DENSITY
DIGITAL I/O PLUG-IN

PUBLICATION NO. 980824-114

EADS North America Defense Test and Services, Inc.
4 Goodyear, Irvine, CA 92618
Tel: (800) 722-2528, (949) 859-8999; Fax: (949) 859-7139

info@eads-nadefense.com
sales@eads-nadefense.com
helpdesk@eads-nadefense.com
<http://www.eads-nadefense.com>



PUBLICATION DATE: November 06, 2002

Copyright 1998 by EADS North America Defense Test and Services, Inc. Printed in the United States of America. All rights reserved. This book or parts thereof may not be reproduced in any form without written permission of the publisher.

**THANK YOU FOR PURCHASING THIS
EADS NORTH AMERICA DEFENSE TEST AND SERVICES PRODUCT**

For this product, or any other EADS North America Defense Test and Services, Inc. product that incorporates software drivers, you may access our web site to verify and/or download the latest driver versions. The web address for driver downloads is:

<http://www.eads-nadefense.com/downloads>

If you have any questions about software driver downloads or our privacy policy, please contact us at

info@eads-nadefense.com

WARRANTY STATEMENT

All EADS North America Defense Test and Services, Inc. products are designed and manufactured to exacting standards and in full conformance to EADS ISO 9001:2000 processes.

This warranty does not apply to defects resulting from any modification(s) of any product or part without EADS North America Defense Test and Services, Inc. express written consent, or misuse of any product or part. The warranty also does not apply to fuses, software, non-rechargeable batteries, damage from battery leakage, or problems arising from normal wear, such as mechanical relay life, or failure to follow instructions.

This warranty is in lieu of all other warranties, expressed or implied, including any implied warranty of merchantability or fitness for a particular use. The remedies provided herein are buyer's sole and exclusive remedies.

For the specific terms of your standard warranty, or optional extended warranty or service agreement, contact your EADS North America Defense Test and Services, Inc. customer service advisor. Please have the following information available to facilitate service.

1. Product serial number
2. Product model number
3. Your company and contact information

You may contact your customer service advisor by:

E-Mail:	Helpdesk@eads-nadefense.com	
Telephone:	+1 800 722 3262	(USA)
Fax:	+1 949 859 7309	(USA)

RETURN of PRODUCT

Authorization is required from EADS North America Defense Test and Services, Inc. before you send us your product for service or calibration. Call or contact the Customer Support Department at 1-800-722-3262 or 1-949-859-8999 or via fax at 1-949-859-7139. We can be reached at: helpdesk@eads-nadefense.com.

PROPRIETARY NOTICE

This document and the technical data herein disclosed, are proprietary to EADS North America Defense Test and Services, Inc., and shall not, without express written permission of EADS North America Defense Test and Services, Inc., be used, in whole or in part to solicit quotations from a competitive source or used for manufacture by anyone other than EADS North America Defense Test and Services, Inc. The information herein has been developed at private expense, and may only be used for operation and maintenance reference purposes or for purposes of engineering evaluation and incorporation into technical specifications and other documents which specify procurement of products from EADS North America Defense Test and Services, Inc.

DISCLAIMER

Buyer acknowledges and agrees that it is responsible for the operation of the goods purchased and should ensure that they are used properly and in accordance with this handbook and any other instructions provided by Seller. EADS North America Defense Test and Services, Inc. products are not specifically designed, manufactured or intended to be used as parts, assemblies or components in planning, construction, maintenance or operation of a nuclear facility, or in life support or safety critical applications in which the failure of the EADS North America Defense Test and Services, Inc. product could create a situation where personal injury or death could occur. Should Buyer purchase EADS North America Defense Test and Services, Inc. product for such unintended application, Buyer shall indemnify and hold EADS North America Defense Test and Services, Inc., its officers, employees, subsidiaries, affiliates and distributors harmless against all claims arising out of a claim for personal injury or death associated with such unintended use.

FOR YOUR SAFETY

Before undertaking any troubleshooting, maintenance or exploratory procedure, read carefully the **WARNINGS** and **CAUTION** notices.



CAUTION
RISK OF ELECTRICAL SHOCK
DO NOT OPEN



This equipment contains voltage hazardous to human life and safety, and is capable of inflicting personal injury.



If this instrument is to be powered from the AC line (mains) through an autotransformer, ensure the common connector is connected to the neutral (earth pole) of the power supply.



Before operating the unit, ensure the conductor (green wire) is connected to the ground (earth) conductor of the power outlet. Do not use a two-conductor extension cord or a three-prong/two-prong adapter. This will defeat the protective feature of the third conductor in the power cord.



Maintenance and calibration procedures sometimes call for operation of the unit with power applied and protective covers removed. Read the procedures and heed warnings to avoid “live” circuit points.

Before operating this instrument:

1. Ensure the proper fuse is in place for the power source to operate.
2. Ensure all other devices connected to or in proximity to this instrument are properly grounded or connected to the protective third-wire earth ground.

If the instrument:

- fails to operate satisfactorily
- shows visible damage
- has been stored under unfavorable conditions
- has sustained stress

Do not operate until, performance is checked by qualified personnel.

Racal Instruments

EC Declaration of Conformity

We

Racal Instruments Inc.
4 Goodyear Street
Irvine, CA 92718

declare under sole responsibility that the

1260-114TTL Digital I/O Module, P/N 407661-001
1260-114MOS Digital I/O Module, P/N 407661-002
1260-114OC Digital I/O Module, P/N 407661-003
1260-114HVOC Digital I/O Module, P/N 407661-004
They conform to the following Product Specifications:

Safety: EN61010-1:1993+A2:1995

EMC: EN61326:1997+A1:1998

Supplementary Information:

The above specifications are met when the product is installed in a Racal Instruments certified mainframe with faceplates installed over all unused slots, as applicable

The product herewith complies with the requirements of the Low Voltage Directive 73/23/EEC and the EMC Directive 89/336/EEC (modified by 93/68/EEC).

Irvine, CA, November 06, 2002

Engineering Director

This page was left intentionally blank.

Table of Contents

Chapter 1	1-1
SPECIFICATIONS	1-1
Introduction – TTL Version	1-1
Specifications – TTL	1-2
Power Dissipation – TTL	1-3
Introduction – CMOS/TTL Version	1-4
Specifications – CMOS/TTL	1-5
Power Dissipation – CMOS/TTL	1-6
Introduction – Standard Open-Collector Version.....	1-7
Specifications – Standard Open Collector.....	1-8
Power Dissipation – Standard Open-Collector.....	1-9
Introduction – High Current/Voltage Open-Collector Version.....	1-10
Specifications – High Current/Voltage Open-Collector	1-11
Power Dissipation – High Current/Voltage Open-Collector	1-12
About MTBF	1-13
Ordering Information	1-13
 Chapter 2	 2-1
INSTALLATION INSTRUCTIONS	2-1
Unpacking and Inspection	2-1
Reshipment Instructions.....	2-1
Installation	2-1

Module Configuration2-2

 Front Panel Connectors.....2-2

 Mating Connectors2-5

Chapter 33-1

MODULE OPERATION3-1

 Setting the Module Address3-1

 Operating Modes.....3-2

 Operating In Message-Based Mode.....3-4

 Port Descriptors For The 1260-1143-4

 Reply To The MOD:LIST? Command.....3-5

 Operating The 1260-114 in Register-Based Mode.....3-5

 1260-114 Example Code3-14

Chapter 44-1

OPTIONAL ASSEMBLIES4-1

Chapter 55-1

PRODUCT SUPPORT5-1

 Product Support5-1

 Warranty.....5-1

List of Figures

Figure 1-1, The 1260-114TTL.....1-1

Figure 1-2, The 1260-114CMOS1-4

Figure 1-3, The 1260-114OC.....1-7

Figure 1-4, The 1260-114HVOC.....1-10

Figure 2-1, Front-Panel Connector Pin Numbering2-3

Figure 2-2, Block Diagram2-5

Figure 3-1, Message-Based Mode of Operation.....3-3

Figure 3-2, Register-Based Mode of Operation.....3-3

List of Tables

Table 2-1, 1260-114 Front-Panel Connections.....2-4

Table 3-1, Register Offset Addresses of the 1260-114 Module.....3-7

Table 3-2, ID Register Functionality of the 1260-1143-8

Table 3-3, Ports A-F Register Functionality of the 1260-114 Module3-8

Table 3-4, Ports G-L Register Functionality of the 1260-114 Module.....3-9

Table 3-5, Control Register 1 Functionality of the 1260-114 Module.....3-10

Table 3-6, Control Register 2 Functionality of the 1260-114 Module.....3-11

Table 3-7, Control Register 3 Functionality of the 1260-114 Module.....3-12

Table 3-8, EPROM Descriptor Functionality of the 1260-114 Module3-12

This page was left intentionally blank.

Chapter 1

SPECIFICATIONS

Introduction – TTL Version

The 1260-114TTL is a plug-in switch module developed for the 1260-100 Adapt-a-Switch Carrier. It switches 96 digital channels that are compliant to both level and current specifications for TTL logic.

The 1260-114TTL includes the following features:

- Standard Adapt-a-Switch™ plug-in design, providing for ease of replacement
- Data-Driven embedded descriptor, allowing immediate use with any Option-01T switch controller, regardless of firmware revision level.

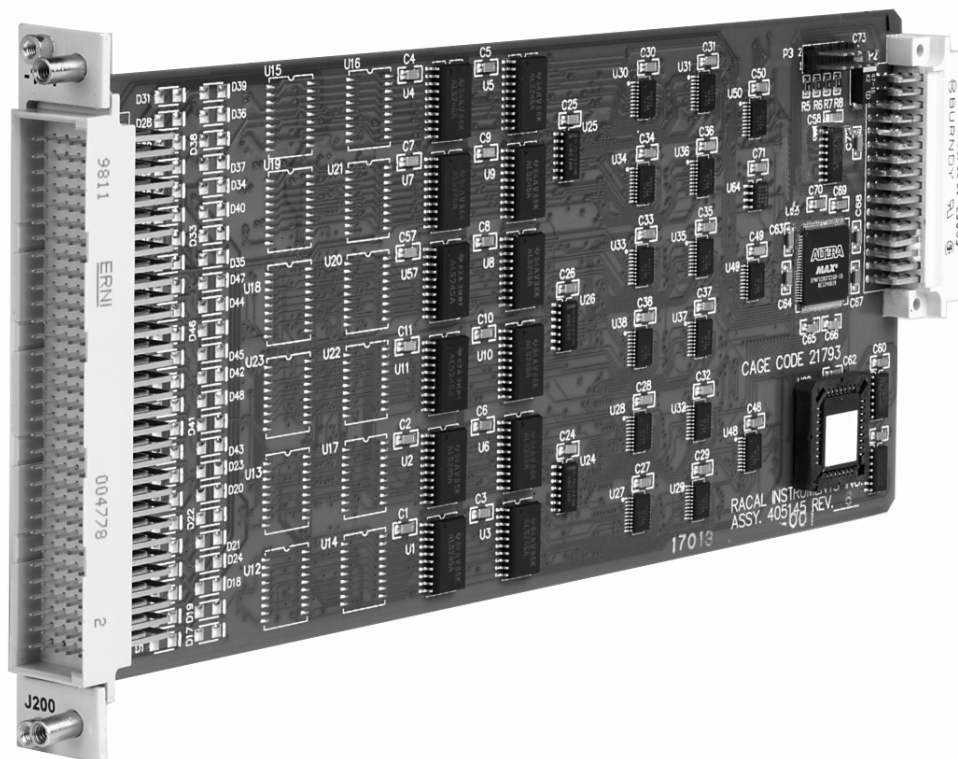

Figure 1-1, The 1260-114TTL

Specifications – TTL

Max. Chan. Input Voltage	5.5 VDC
Chan. Output Current	±30 mA maximum
Min. High Output Voltage	≥ 2 VDC @ -15 mA
Max. Low Output Voltage	≤ 0.5 VDC @ 24 mA
Available I/O Channels	96 Bi-directional I/O
Channel Synchronization	Asynchronous, Synchronous or Mixed
Synchronous Trigger Handshake Polarity	User Programmable
Synchronous Busy Handshake Polarity	User Programmable
Shock	30g, 11 ms, ½ sine wave
Vibration	0.013 in. P-P, 5-55 Hz
Bench Handling	4 in., 45°
Cooling	See 1260-100 cooling data
Temperature	
Operating	0°C to +55°C
Non-operating	-40°C to +75°C
Relative Humidity	85% + 5% non-condensing at < 30°C
Altitude	
Operating	10,000 feet
Non-operating	15,000 feet
Power Requirements +5 VDC	2.5 A maximum with all channels sourcing maximum current
Weight	6 oz. (0.21 kg.)
Mean Time Between Failures (MTBF)	>100,000 hours (MIL-HDBK-217E)
Mean Time to Repair	< 5 minutes (MTTR)

Power Dissipation – TTL

The cooling of the Adapt-a-Switch carrier is dependent upon the chassis into which it is installed. The carrier can nominally dissipate approximately 100 W. Even with all channels driven to maximum outputs, up to six 1260-114 TTL plug-ins may be used together in a 1260-100 without exceeding the maximum allowable power dissipation of the carrier.

If the 1260-114TTL will be used in conjunction with other cards, the 1260-114TTL dissipation should be computed and summed with the total worst-case dissipation of the remaining modules.

For example, a 1260-114TTL module would dissipate the following energy:

Quiescent power dissipation = 4.25W maximum

Channel dissipation =
[(Vcc – 2.25) * current * 96(# channels energized)] +
[(current)² * (path resistance) * 96(# channels energized)]

Total Power Dissipation = Quiescent + Channel

Assuming all 96 channels are sourcing a maximum current of 30 mA and a path resistance of 1Ω:

Total power dissipation =
[(5 VDC - 2.25) * 0.030 A * 96] + [(0.030 A)² * (1 Ω) * 96]
+ (4.25 W) = 12.25 W at 55°C

This is acceptable power dissipation for an individual plug-in module. If five additional modules are likewise loaded, then the overall carrier dissipation is approximately 74 W, which is well within the cooling available in most commercial VXIbus chassis. In practice, rarely are more than 25% of the module's channels energized simultaneously, and rarely is full rated current run through every path. Using the 25% rule, the power dissipated by each plug-in should be no more than 3 W. If all six slots are used simultaneously, this would amount to a total dissipation of 18Watts.

Additionally, if fewer plug-in modules are used, more power may be dissipated by the remaining cards. By using a chassis with high cooling capacity, such as the 1261B, almost any configuration may be realized.

Introduction – CMOS/TTL Version

The 1260-114CMOS is a plug-in switch module developed for the 1260-100 Adapt-a-Switch Carrier. It switches 96 digital channels that are compliant to both level and current specifications for CMOS. The 1260-114CMOS is also TTL-level compliant, but at a reduced sink and source current. For applications requiring TTL-level compliance at higher currents, the 1260-114TTL should be selected.

The 1260-114CMOS includes the following features:

- Standard Adapt-a-Switch™ plug-in design, providing for ease of replacement
- Data-Driven embedded descriptor, allowing immediate use with any Option-01T switch controller, regardless of firmware revision level.

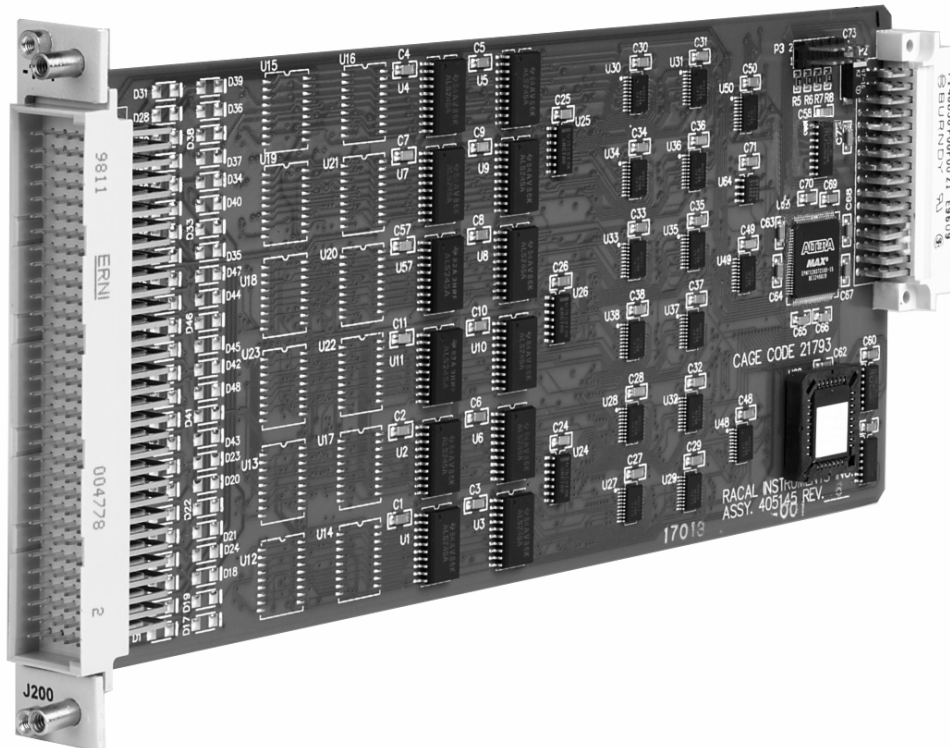

Figure 1-2, The 1260-114CMOS

**Specifications –
CMOS/TTL**

Max. Chan. Input Voltage	5.5 VDC
Chan. Output Current	±8 mA maximum
Min. High Output Voltage	≥ 3.8 VDC @ -8 mA
Max. Low Output Voltage	≤ 0.44 VDC @ 8 mA
Available I/O Channels	96 Bi-directional I/O
Channel Synchronization	Asynchronous, Synchronous or Mixed
Synchronous Trigger Handshake Polarity	User Programmable
Synchronous Busy Handshake Polarity	User Programmable
Shock	30g, 11 ms, ½ sine wave
Vibration	0.013 in. P-P, 5-55 Hz
Bench Handling	4 in., 45°
Cooling	See 1260-100 cooling data
Temperature	
Operating	0°C to +55°C
Non-operating	-40°C to +75°C
Relative Humidity	85% + 5% non-condensing at < 30°C
Altitude	
Operating	10,000 feet
Non-operating	15,000 feet
Power Requirements +5 VDC	1 A maximum with all channels sourcing maximum loads
Weight	6 oz. (0.21 kg.)
Mean Time Between Failures (MTBF)	>100,000 hours (MIL-HDBK-217E)
Mean Time to Repair	< 5 minutes (MTTR)

Power Dissipation – CMOS/TTL

The cooling of the Adapt-a-Switch carrier is dependent upon the chassis into which it is installed. The carrier can nominally dissipate approximately 100 W. Even with all channels driven to maximum outputs, up to six 1260-114CMOS plug-ins may be used together in a 1260-100 without exceeding the maximum allowable power dissipation of the carrier.

While the cooling of the Adapt-a-Switch carrier is dependent upon the chassis into which it is installed, the carrier can normally dissipate approximately 100 W. Care must be taken, then, in the selection and loading of the plug-in modules used in the carrier. With the 1260-114CMOS it is not possible to fully load the carrier with these cards, drive every channel at full load and exceed the power dissipation capabilities of the Adapt-a-Switch carrier.

If the 1260-114CMOS will be used in conjunction with other cards, the 1260-114CMOS dissipation should be computed and summed with the total worst-case dissipation of the remaining modules.

For example, a 1260-114CMOS module would dissipate the following energy:

Quiescent power dissipation = 0.75W maximum

Channel dissipation =
 $[(V_{cc} - 3.8) * \text{current} * 96(\# \text{ channels energized})] +$
 $[(\text{current})^2 * (\text{path resistance}) * 96(\# \text{ channels energized})]$

Total Power Dissipation = Quiescent + Channel

Assuming all 96 channels are sourcing a maximum current of 8 mA and a path resistance of 1Ω:

Total power dissipation =
 $[(5 \text{ VDC} - 3.8) * 0.008 \text{ A} * 96] + [(0.008 \text{ A})^2 * (1 \Omega) * 96]$
 $+ (0.75 \text{ W}) = 1.7 \text{ W at } 55^\circ\text{C}$

This is acceptable power dissipation for an individual plug-in module. If five additional modules are likewise loaded, then the overall carrier dissipation is approximately 10 W, which is well within the cooling available in most commercial VXIbus chassis. In practice, rarely are more than 25% of the module's channels energized simultaneously, and rarely is full rated current run through every path. Using the 25% rule, the power dissipated by each plug-in should be no more than 0.5 W. If all six slots are used simultaneously, this would amount to a total dissipation of 2.5Watts.

Additionally, if fewer plug-in modules are used, more power may be dissipated by the remaining cards. By using a chassis with high cooling capacity, such as the 1261B, almost any configuration may be realized.

Introduction – Standard Open- Collector Version

The 1260-114OC is a plug-in switch module developed for the 1260-100 Adapt-a-Switch Carrier. It switches 96 open-collector channels at 200 mA per channel. The 1260-114OC includes the following features:

- Standard Adapt-a-Switch™ plug-in design, providing for ease of replacement
- Data-Driven embedded descriptor, allowing immediate use with any Option-01T switch controller, regardless of firmware revision level.

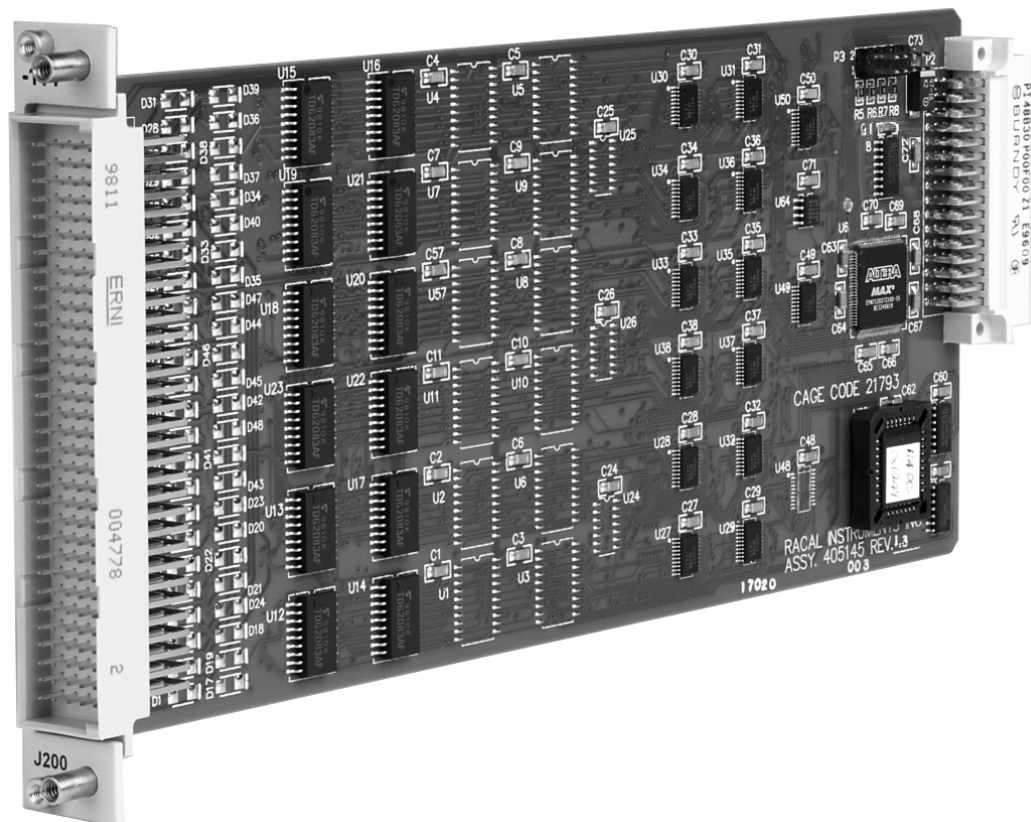

Figure 1-3, The 1260-114OC

Specifications – Standard Open Collector

Max. Chan. Input Voltage	32 VDC
Chan. Output Current	200 mA maximum
High Output Voltage	$5 \leq V_{oh} \leq 32$ VDC
Max. Low Output Voltage	≤ 1.5 VDC @ 200 mA
Available I/O Channels	96 open-collector channels
Channel Synchronization	Asynchronous, Synchronous or Mixed
Synchronous Trigger Handshake Polarity	User Programmable
Synchronous Busy Handshake Polarity	User Programmable
Shock	30g, 11 ms, ½ sine wave
Vibration	0.013 in. P-P, 5-55 Hz
Bench Handling	4 in., 45°
Cooling	See 1260-100 cooling data
Temperature	
Operating	0°C to +55°C
Non-operating	-40°C to +75°C
Relative Humidity	85% + 5% non-condensing at < 30°C
Altitude	
Operating	10,000 feet
Non-operating	15,000 feet
Power Requirements +5 VDC	0.5 A maximum
Weight	6 oz. (0.21 kg.)
Mean Time Between Failures (MTBF)	>100,000 hours (MIL-HDBK-217E)
Mean Time to Repair	< 5 minutes (MTTR)

Power Dissipation – Standard Open- Collector

The cooling of the Adapt-a-Switch carrier is dependent upon the chassis into which it is installed. The carrier can nominally dissipate approximately 100 W. Even with all channels driven to maximum outputs, up to six 1260-114OC plug-ins may be used together in a 1260-100 without exceeding the maximum allowable power dissipation of the carrier.

If the 1260-114OC will be used in conjunction with other cards, the 1260-114OC dissipation should be computed and summed with the total worst-case dissipation of the remaining modules.

For example, a 1260-114OC module would dissipate the following energy:

Quiescent power dissipation = 0.75W maximum

Channel dissipation =
[(Vol) * current * 96(# channels energized)] +
[(current)² * (path resistance) * 96(# channels energized)]

Total Power Dissipation = Quiescent + Channel

Assuming all 96 channels are sinking a maximum current of 200 mA and a path resistance of 0.5 Ω:

Total power dissipation =
[(1.5) * 0.200 A * 96] + [(0.200 A)² * (0.5 Ω) * 96]
+ (0.75 W) = 31.5 W at 55°C

This exceeds the acceptable power dissipation for an individual plug-in module. If five additional modules are likewise loaded, then the overall carrier dissipation is approximately 188 W, which is above the typical cooling capabilities of the carrier and most chassis in a two slot configuration. Therefore using a fully loaded Adapt-a-Switch carrier with these cards operating at the maximum extreme is not permissible. In practice, however, rarely are more than 25% of the module's channels energized simultaneously, and rarely is full rated current run through every path. In addition, temperatures are typically not run at the rated maximum. Using the 25% rule, the power dissipated by each plug-in should be no more than 8 W. If all six slots are used simultaneously, this would amount to a total dissipation of 48Watts.

Additionally, if fewer plug-in modules are used, more power may be dissipated by the remaining cards. By using a chassis with high cooling capacity, such as the 1261B, almost any configuration may be realized.

Introduction – High Current/Voltage Open-Collector Version

The 1260-114HVOC is a plug-in switch module developed for the 1260-100 Adapt-a-Switch Carrier. It switches 48 open-collector channels at 50V and 1.5 A per channel. The 1260-114HVOC includes the following features:

- Standard Adapt-a-Switch™ plug-in design, providing for ease of replacement
- Data-Driven embedded descriptor, allowing immediate use with any Option-01T switch controller, regardless of firmware revision level.

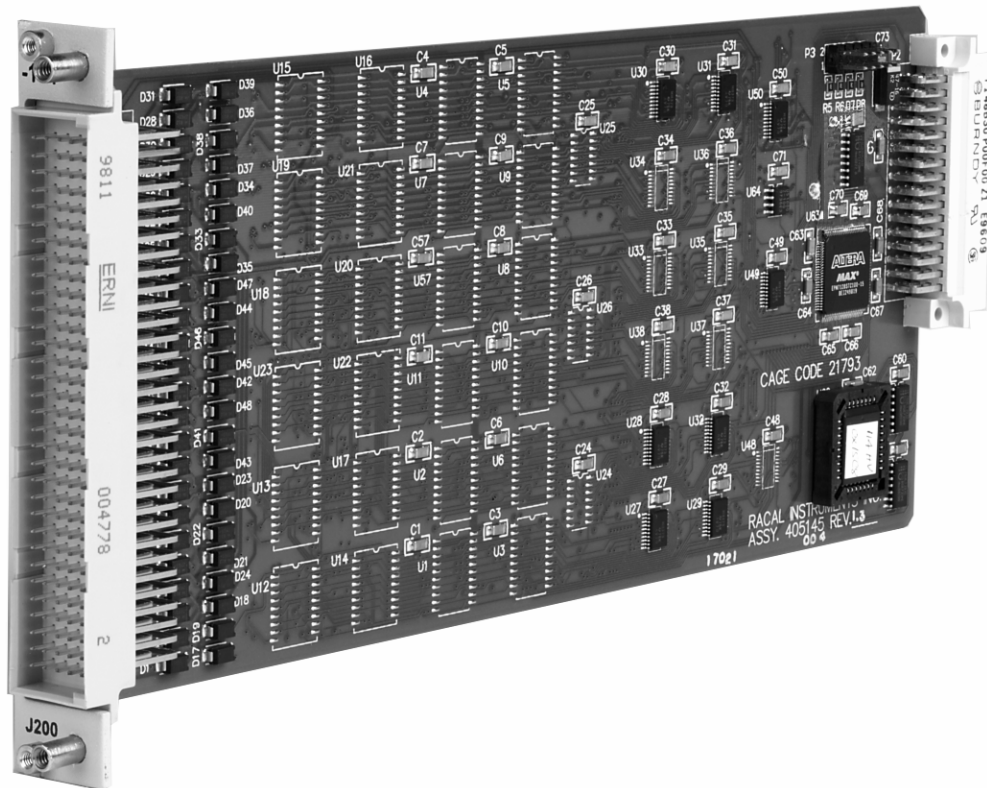

Figure 1-4, The 1260-114HVOC

**Specifications –
High
Current/Voltage
Open-Collector**

Max. Chan. Input Voltage	50 VDC
Chan. Output Current	1.5 A maximum
High Output Voltage	$2 \leq V_{oh} \leq 50$ VDC
Max. Low Output Voltage	≤ 0.5 VDC @ 1.5 A
Available I/O Channels	48 open-collector channels
Channel Synchronization	Asynchronous, Synchronous or Mixed
Synchronous Trigger Handshake Polarity	User Programmable
Synchronous Busy Handshake Polarity	User Programmable
Shock	30g, 11 ms, ½ sine wave
Vibration	0.013 in. P-P, 5-55 Hz
Bench Handling	4 in., 45°
Cooling	See 1260-100 cooling data
Temperature	
Operating	0°C to +55°C
Non-operating	-40°C to +75°C
Relative Humidity	85% + 5% non-condensing at < 30°C
Altitude	
Operating	10,000 feet
Non-operating	15,000 feet
Power Requirements +5 VDC	0.5 A maximum
Weight	6 oz. (0.21 kg.)
Mean Time Between Failures (MTBF)	>100,000 hours (MIL-HDBK-217E)
Mean Time to Repair	< 5 minutes (MTTR)

Power Dissipation – High Current/Voltage Open-Collector

The cooling of the Adapt-a-Switch carrier is dependent upon the chassis into which it is installed. The carrier can nominally dissipate approximately 100 W. Even with all channels driven to maximum outputs, up to six 1260-114 TTLHVOC plug-ins may be used together in a 1260-100 without exceeding the maximum allowable power dissipation of the carrier.

If the 1260-114HVOC will be used in conjunction with other cards, the 1260-114HVOC dissipation should be computed and summed with the total worst-case dissipation of the remaining modules.

For example, a 1260-114HVOC module would dissipate the following energy:

Quiescent power dissipation = 0.75W maximum

Channel dissipation =
 $[(R_{ds}) * (\text{current})^2 * 48(\# \text{ channels energized})] +$
 $[(\text{current})^2 * (\text{path resistance}) * 48(\# \text{ channels energized})]$

Total Power Dissipation = Quiescent + Channel

Assuming all 48 channels are sinking a maximum current of 1.5 A and a path resistance of 0.030 Ω :

Total power dissipation =
 $[(1.5 \text{ A})^2 * (0.060 \Omega) * 48] + [(1.5 \text{ A})^2 * (0.070 \Omega) * 48]$
 + (0.75 W) = 15 W at 55°C

This is acceptable power dissipation for an individual plug-in module. If five additional modules are likewise loaded, then the overall carrier dissipation is approximately 89 W, which is well within the cooling available in most commercial VXIbus chassis. In practice, rarely are more than 25% of the module's channels energized simultaneously, and rarely is full rated current run through every path. Using the 25% rule, the power dissipated by each plug-in should be no more than 3.75 W. If all six slots are used simultaneously, this would amount to a total dissipation of about 23Watts.

Additionally, if fewer plug-in modules are used, more power may be dissipated by the remaining cards. By using a chassis with high cooling capacity, such as the 1261B, almost any configuration may be realized.

About MTBF

The 1260-114 MTBF is 783,668 hours, calculated in accordance with MIL-HDBK-217E.

Ordering Information

Listed below are part numbers for both the 1260-114 switch module and available mating connector accessories. Each 1260-114 uses a single mating connector.

ITEM	DESCRIPTION	PART #
1260-114TTL Switch Module	Switch Module, 96-Channel TTL Digital Output Consists of: P/N 405145-001 PCB Assy P/N 980824-114 Manual	407661-001
1260-114CMOS Switch Module	Switch Module, 96-Channel CMOS Digital Output Consists of: P/N 405145-002 PCB Assy P/N 980824-114 Manual	407661-002
1260-114OC Switch Module	Switch Module, 96-Channel Standard Open-Collector Output Consists of: P/N 405145-003 PCB Assy P/N 980824-114 Manual	407661-003
1260-114HVOC Switch Module	Switch Module, 48-Channel High Current/Voltage Open-Collector Output Consists of: P/N 405145-004 PCB Assy P/N 980824-114 Manual	407661-004
160-pin Mating Connector	160 Pin Conn. Kit with pins	407664
Cable Assy. 6ft, Sleeved	160 Pin Cable Assy, 6 Ft, 24 AWG	407408-001
Connector Bracket	Bracket, Strain Relief	456673
Additional Manual		980824-114

This page was left intentionally blank.

INSTALLATION INSTRUCTIONS

Unpacking and Inspection



1. Remove the 1260-114 module and inspect it for damage. If any damage is apparent, inform the carrier immediately. Retain shipping carton and packing material for the carrier's inspection.
2. Verify that the pieces in the package you received contain the correct 1260-114 module option and the 1260-114 Users Manual. Notify EADS North America Defense Test and Services, Inc. if the module appears damaged in any way. Do not attempt to install a damaged module into a VXI chassis.
3. The 1260-114 module is shipped in an anti-static bag to prevent electrostatic damage to the module. Do not remove the module from the anti-static bag unless it is in a static-controlled area.

Reshipment Instructions

1. Use the original packing when returning the switching module to EADS North America Defense Test and Services, Inc. for calibration or servicing. The original shipping carton and the instrument's plastic foam will provide the necessary support for safe reshipment.
2. If the original packing material is unavailable, wrap the switching module in an ESD Shielding bag and use plastic spray foam to surround and protect the instrument.
3. Reship in either the original or a new shipping carton.

Installation

Installation of the 1260-114 Switching Module into a 1260-100 Carrier assembly is described in the Installation section of the 1260-100 Adapt-a-Switch Carrier Manual.

Module Configuration

The 1260-114 is an 96-channel (48-channel for HVOC version), digital I/O plug-in for the Adapt-a-Switch Series. Its architecture permits any 8-bit port to be defined through software as in input or output in either asynchronous or synchronous operational mode. For the open-collector versions, the ports can be used as inputs by setting the transistors in an off state.

Front Panel Connectors

The 1260-114 has one 160-pin front-panel connector, labeled J200. It is a 160-pin, modified DIN style, with 0.025" square posts as pins. It has one pin for each input and one for each output. See **Figure 2-1** for pin numbering. **Table 2-1** shows the mapping of channel numbers to connector pins. Information about available mating connectors is provided immediately after **Table 2-1**.

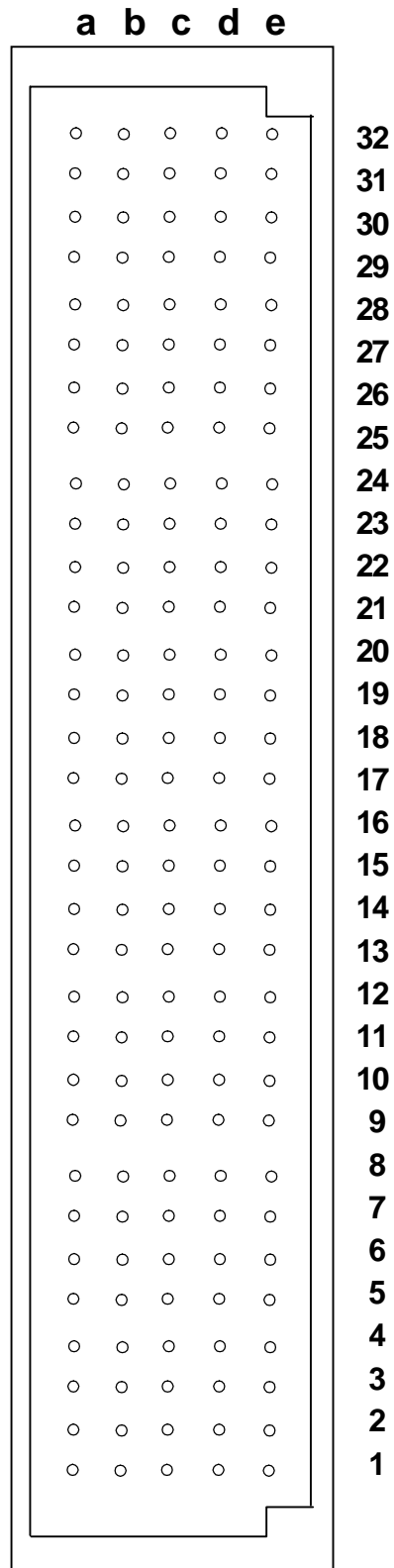

Figure 2-1, Front-Panel Connector Pin Numbering

Table 2-1, 1260-114 Front-Panel Connections

Pin #	Connector Pin Descriptions				
	Row A	Row B	Row C	Row D	Row E
1	A0	C0	E0	Hi-Z (Fly) A ‡	Hi-Z (Fly) B ‡
2	A1	C1	E1	GND	GND
3	A2	C2	E2	GND	GND
4	A3	C3	E3	GND	GND
5	A4	C4	E4	Hi-Z (Fly) C ‡	Hi-Z (Fly) D ‡
6	A5	C5	E5	GND	GND
7	A6	C6	E6	GND	GND
8	A7	C7	E7	GND	GND
9	B0	D0	F0	Hi-Z (Fly) E ‡	Hi-Z (Fly) F ‡
10	B1	D1	F1	GND	GND
11	B2	D2	F2	GND	GND
12	B3	D3	F3	GND	GND
13	B4	D4	F4	Hi-Z (Fly) G ‡	Hi-Z (Fly) H ‡
14	B5	D5	F5	GND	GND
15	B6	D6	F6	GND	GND
16	B7	D7	F7	GND	GND
17	G0 (GND) †	I0 (GND) †	K0 (GND) †	Hi-Z (Fly) I ‡	Hi-Z (Fly) J ‡
18	G1 (GND) †	I1 (GND) †	K1 (GND) †	GND	GND
19	G2 (GND) †	I2 (GND) †	K2 (GND) †	GND	GND
20	G3 (GND) †	I3 (GND) †	K3 (GND) †	GND	GND
21	G4 (GND) †	I4 (GND) †	K4 (GND) †	Hi-Z (Fly) K ‡	Hi-Z (Fly) L ‡
22	G5 (GND) †	I5 (GND) †	K5 (GND) †	GND	GND
23	G6 (GND) †	I6 (GND) †	K6 (GND) †	GND	GND
24	G7 (GND) †	I7 (GND) †	K7 (GND) †	GND	GND
25	H0 (GND) †	J0 (GND) †	L0 (GND) †	EXTBUSY	EXTCLKIN
26	H1 (GND) †	J1 (GND) †	L1 (GND) †	GND	GND
27	H2 (GND) †	J2 (GND) †	L2 (GND) †	GND	GND
28	H3 (GND) †	J3 (GND) †	L3 (GND) †	GND	GND
29	H4 (GND) †	J4 (GND) †	L4 (GND) †	GND	GND
30	H5 (GND) †	J5 (GND) †	L5 (GND) †	GND	GND
31	H6 (GND) †	J6 (GND) †	L6 (GND) †	GND	GND
32	H7 (GND) †	J7 (GND) †	L7 (GND) †	GND	GND

† For the 1260-114HVOC version these pins are tied to ground.

‡ For the 1260-114TTL and 1260-114CMOS, these pins act as external tri-state inputs (active low) for the indicated ports. For the 1260-114OC and 1260-114HVOC, these pins connect to the fly-back protection diodes assigned to the indicated ports. Pins for Ports G-L are not connected in the 1260-114HVOC version.

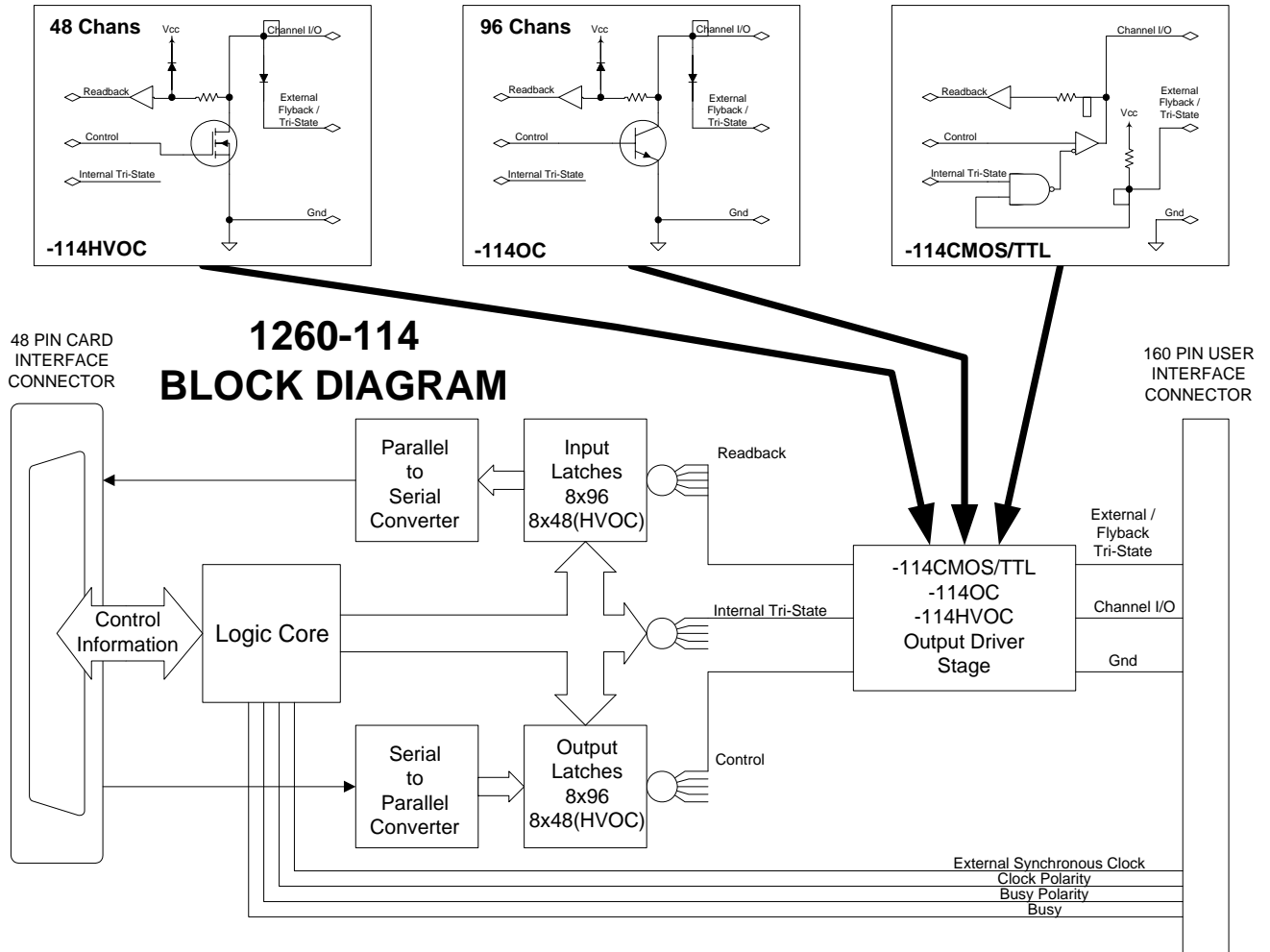

Figure 2-2, Block Diagram

Mating Connectors

Mating connector accessories are available:

160-Pin Connector Kit with backshell and pins,
P/N407664

160-Pin Cable Assembly, 6 Ft., 24 AWG,
P/N 407408-001

The 160-Pin Connector Kit consists of a connector housing, and 170 crimp pins. After wire attachment, the pin is inserted into the housing and will snap into place, providing positive retention.

The suggested hand tool for the crimp pins is P/N 990898. The corresponding pin removal tool is P/N 990899.

The 160-Pin Cable Assembly uses 24 AWG cable with crimp pins to mate with the 1260-114. The other cable end is un-terminated. Refer to **Table 2-1** for channel-to-pin mapping information.

This page was left intentionally blank.

Chapter 3

MODULE OPERATION

Setting the Module Address

The Option-01T switch controller identifies each Adapt-a-Switch plug-in or conventional 1260-Series module by a *module address* that is unique to that module. The module address is a number from 1 through 12, inclusive.

The module address assigned to the 1260-114 depends on the carrier slot into which the 1260-114 is inserted, and on the position of the logical address DIP switch on the carrier side panel. The switch has two settings:

- 1-6 (closed): When the switch is set to this position, the module addresses of the plug-ins in the 1260-100 Carrier are from 1 through 6. The module with address 1 is in the left slot of the top row. The plug-ins are addressed in the following pattern:

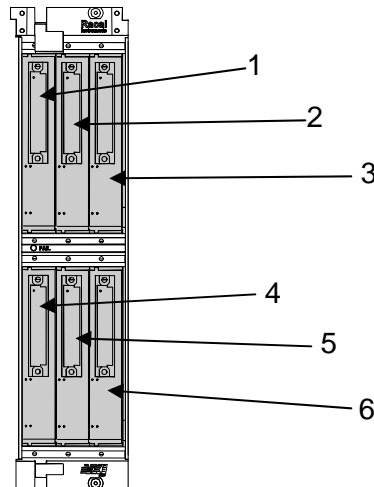

Front View – Module Addresses for 1 through 6

- 7 - 12 (open): When the switch is set to this position, the module addresses of the plug-ins in the 1260-100 Carrier are from 7 through 12, in the following pattern:

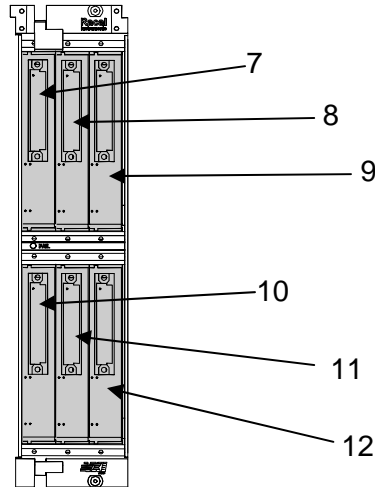

Front View – Module Addresses for 7 through 12

When setting module addresses for Adapt-a-Switch Carriers and conventional 1260-Series modules, be sure that no address is used by more than one plug-in or 1260-Series module.

For instructions on setting module addresses for a conventional 1260-Series module, see the label on the side panel of the module.

Operating Modes

The 1260-114 may be operated either in *message-based* mode or in *register-based* mode.

In the *message-based* mode, the 1260-01T switch controller interprets commands sent by the slot 0 controller, and determines the appropriate data to send to the control registers of the 1260-114 module.

If the A24 VXI base address for the 1260-100 Adapt-A-Switch carrier is assumed to be at 0x804000A for example purposes and the 1260-114 occupies the module 0 slot, **Figure 3-1** below provides a conceptual view of the message-based mode of operation for a read operation on port 1.

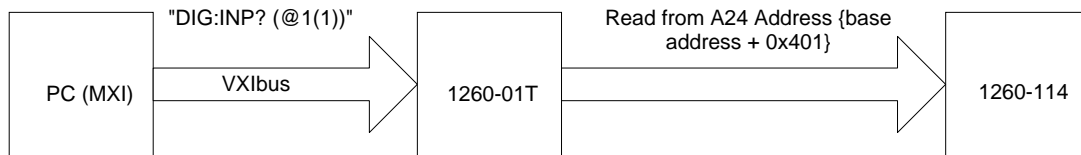

Figure 3-1, Message-Based Mode of Operation

In the *register-based* mode, the user writes directly to the port registers on the 1260-114 module. The 1260-01T command module does not monitor these operations, and does not keep track of the port states on the 1260-114 module in this mode.

A conceptual view of the register-based mode is shown in **Figure 3-2** below.

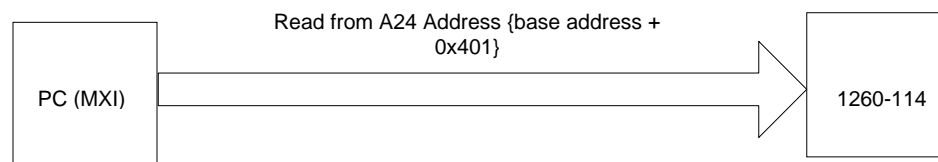

Figure 3-2, Register-Based Mode of Operation

Since the 1260-01T switch controller does not keep track of port and control register states during the register-based mode, it is advisable to use **either** the message-based or the register-based mode consistently, and use the chosen mode exclusively throughout the application program.

In general, the message-based mode of operation is easier to use with utility software such as the National Instruments VXI Interactive Control (VIC) program. The message-based mode allows the user to send ASCII text commands to the 1260-01T and to read replies from the 1260-01T. In addition, some features, such as synchronous port operation, are available only in the message-based mode. An added benefit of message-based operation is that it obviates the need to manually configure control registers on the 1260-114, controlling such things as port data direction, since these are handled automatically by the 1260-01T.

The register-based mode provides faster and more direct control of the 1260-114. In this mode, direct port and control register operations are processed in less than 9 microseconds, not counting software overhead inherent in I/O libraries such as VISA.

For further information about message-based vs. register-based comparisons, consult the 1260-01T User's Manual for further details.

Operating In Message-Based Mode

Port Descriptors For The 1260-114

The standard 1260-01T commands are used to operate the 1260-114 module. These commands are described in the 1260-01T User's Manual.

Each 1260-01T port command uses a *port descriptor* (also referred to as a *channel descriptor* in some documentation) to select the port(s) of interest. The syntax for a port descriptor is the same for all 1260 series modules. In general, the following syntax is used to select a single port:

```
(@ <module address> ( <port> ) )
```

Where:

- <module address> is the address of the 1260-114 module. This is a number in the range from 1 through 12, inclusive.
- <port> is the 1260-114 port to operate. This is a number in the range from 0 through 11, inclusive for the 1260-114TTL, -114CMOS and -114OC versions and 0 through 5, inclusive for the 1260-114HVOC.

Multiple individual ports may be specified using the following port descriptor syntax:

```
@ <module address> ( <port1> , <port2>  
, . . . , <portN> ) [,data]
```

A range of ports may be specified using the following channel descriptor syntax:

```
@ <module address> ( <first port> :  
<last port> ) )
```

The following examples illustrate the use of the port descriptors for

the 1260-114:

DIG:OUTP (@8(0)),234 Writes 234d to port 0 at
module address 8

DIG:INP? (@3(1)) Reads port 1 at module address 3

Reply To The MOD:LIST? Command

The 1260-01T returns a reply to the MOD:LIST? command. This reply is unique for each different 1260 series switch module. The syntax for the reply is:

<module address> : <module-specific identification string>

The <module-specific identification string> for the 1260-114 depends on the version. For the TTL, CMOS, standard open-collector and high voltage/current open collector, the strings are respectively:

1260-114TTL DIGITAL INPUT/OUTPUT TTL MODULE

1260-114CM DIGITAL INPUT/OUTPUT CMOS MODULE

1260-114OC DIGITAL INPUT/OUTPUT OPEN
COLLECTOR MODULE

1260-114HV DIGITAL INPUT/OUTPUT HIGH VOLTAGE
OPEN COLLECTOR MODULE

So, for a 1260-114TTL whose <module address> is set to 8, the reply to this query would be:

8 : 1260-114TTL DIGITAL INPUT/OUTPUT TTL
MODULE

Operating The 1260-114 in Register-Based Mode

In register-based mode, the 1260-114 is operated by directly writing and reading to port and control registers on the 1260-114 module. To access the various registers the following details must be assembled to generate an absolute address that can be wrote or read from:

The port and control registers are located in the VXIbus A24 Address Space. The A24 address for a port or control register depends on:

1. The A24 Address Offset assigned to the 1260-01T module by the Resource Manager program. The Resource Manager program is provided by the VXIbus slot-0 controller vendor. The A24 Address Offset is placed into the "Offset Register" of the 1260-01T by the Resource Manager.
2. The <module address> of the 1260-114 module. This is a

value in the range from 1 and 12 inclusive.

3. The 1260-114 port or control register to be written to or read from. Each register on the 1260-114 has a unique offset from the base address.

The base A24 address for the 1260-114 module may be calculated by:

$$(A24 \text{ Offset of the } 1260-01T) + (1024 \times \text{Module Address of } 1260-114).$$

The A24 address offset is usually expressed in hexadecimal. A typical value of 204000_{16} is used in the examples that follow.

A 1260-114 with a module address of 7 would have the base A24 address computed as follows:

$$\begin{aligned} \text{Base A24 Address of } 1260-114 &= 204000_{16} + (400_{16} \times 7_{10}) \\ &= 205C00_{16} \end{aligned}$$

The port and control registers for Adapt-a-Switch plug-ins and conventional 1260-Series modules are always on odd-numbered A24 addresses. For port registers, the 1260-114 reads and writes to the same location. For control registers, the 1260-114 writes to one location, but reads back from another. **Table 3-1** provides offsets relative to the base address of the module for all port and control registers of the 1260-114. To obtain the absolute address where data is to be written or read from, the base address is added to the offset:

$$(\text{Base A24 } 1260-114 \text{ Address}) + \text{offset} = \text{absolute address}$$

So, for our example base A24 address computed earlier, the following absolute addresses would apply for the operations indicated:

205C01	Port 0 read or written at this location
205C19	Control Register 1 written at this location
205E03	Control Register 1 read at this location

Before explaining the particulars of reading and writing to port and control registers, it is necessary to understand how the registers interact with the 1260-114. **Table 3-2** provides a detailed explanation of each register and how it interacts with the 1260-114 module.

Table 3-1, Register Offset Addresses of the 1260-114 Module

Register Name	Register Offsets to Add to Base Module Address	
	Write Location (hexadecimal)	Read Location (hexadecimal)
Port A (Port 0)	0x01	0x01
Port B (Port 1)	0x03	0x03
Port C (Port 2)	0x05	0x05
Port D (Port 3)	0x07	0x07
Port E (Port 4)	0x09	0x09
Port F (Port 5)	0x0B	0x0B
Port G (Port 6)	0x0D	0x0D
Port H (Port 7)	0x0F	0x0F
Port I (Port 8)	0x11	0x11
Port J (Port 9)	0x13	0x13
Port K (Port 10)	0x15	0x15
Port L (Port 11)	0x17	0x17
ID	Read Only	0x201
Control Register 1	0x19	0x203
Control Register 2	0x1B	0x205
Control Register 3	0x1D	0x207
EPROM Descriptor	Read Only	0x301

Table 3-2, ID Register Functionality of the 1260-114

Register Table		ID Register
Module Version	Bit	Functionality Description
TTL, CMOS, OC and HVOC	0	Always Reads 0x00 (Read Only)
	1	
	2	
	3	
	4	
	5	
	6	
	7	

Table 3-3, Ports A-F Register Functionality of the 1260-114 Module

Register Table		Ports A-F
Module Version	Bit	Functionality Description
TTL and CMOS	0	Each port is an 8-bit register where the lowest order bit corresponds to lowest order connector pin of the port group. A '1' written to any bit drives the appropriate output driver high while a '0' drives the appropriate output driver low. If a port is read, the data will appear identical to what was written to the register.
	1	
	2	
	3	
	4	
	5	
	6	
	7	
OC and HVOC	0	Each port is an 8-bit register where the lowest order bit corresponds to lowest order connector pin of the port group. A '1' written to any bit enables the appropriate open-collector output transistor while a '0' disables the appropriate open-collector output transistor. If a port is read, the data will appear inverted from what was written to the register, assuming the external power supply pulls up the collector output of the transistor through the external load
	1	
	2	
	3	
	4	
	5	
	6	
	7	

Table 3-4, Ports G-L Register Functionality of the 1260-114 Module

Register Table		Ports G-L
Module Version	Bit	Functionality Description
TTL and CMOS	0	Each port is an 8-bit register where the lowest order bit corresponds to lowest order connector pin of the port group. A '1' written to any bit drives the appropriate output driver high while a '0' drives the appropriate output driver low. If a port is read, the data will appear identical to what was written to the register.
	1	
	2	
	3	
	4	
	5	
	6	
	7	
OC	0	Each port is an 8-bit register where the lowest order bit corresponds to lowest order connector pin of the port group. A '1' written to any bit enables the appropriate open-collector output transistor while a '0' disables the appropriate open-collector output transistor. If a port is read, the data will appear inverted from what was written to the register, assuming the external power supply pulls up the collector output of the transistor through the external load
	1	
	2	
	3	
	4	
	5	
	6	
	7	
HVOC	0	Not Used
	1	Not Used
	2	Not Used
	3	Not Used
	4	Not Used
	5	Not Used
	6	Not Used
	7	Not Used

Table 3-5, Control Register 1 Functionality of the 1260-114 Module

Register Table		Control Register 1	
Module Version	Bit	Functionality Description	
TTL and CMOS (As written to register: bits normally read inverted unless external port tri-state pin is '0' in which case bit will always read a '1')	0	0: Port A Input Port	1: Port A Output Port
	1	0: Port B Input Port	1: Port B Output Port
	2	0: Port C Input Port	1: Port C Output Port
	3	0: Port D Input Port	1: Port D Output Port
	4	0: Port E Input Port	1: Port E Output Port
	5	0: Port F Input Port	1: Port F Output Port
	6	0: Port G Input Port	1: Port G Output Port
	7	0: Port H Input Port	1: Port H Output Port
OC and HVOC	0	Not Used	
	1	Not Used	
	2	Not Used	
	3	Not Used	
	4	Not Used	
	5	Not Used	
	6	Not Used	
	7	Not Used	

Table 3-6, Control Register 2 Functionality of the 1260-114 Module

Register Table		Control Register 2	
Module Version	Bit	Functionality Description	
TTL and CMOS (As written to register: bits 0-3 normally read inverted unless external port tri-state pin is '0' in which case bit will always read a '1')	0	0: Port I Input Port	1: Port I Output Port
	1	0: Port J Input Port	1: Port J Output Port
	2	0: Port K Input Port	1: Port K Output Port
	3	0: Port L Input Port	1: Port L Output Port
	4	Bits 4-7 control whether ports A-L act in synchronous or asynchronous mode. Bits 4-7 enable synchronous mode for the port specified and all lower order ports while higher ports are set to asynchronous mode (i.e. 0x0 = all ports asynchronous, 0xB = all ports synchronous, 0x3 = ports A-C synchronous)	
	5		
	6		
	7		
OC	0	Not Used	
	1	Not Used	
	2	Not Used	
	3	Not Used	
	4	Bits 4-7 control whether ports A-L act in synchronous or asynchronous mode. Bits 4-7 enable synchronous mode for the port specified and all lower order ports while higher ports are set to asynchronous mode (i.e. 0x0 = all ports asynchronous, 0xB = all ports synchronous, 0x3 = ports A-C synchronous)	
	5		
	6		
	7		
HVOC	0	Not Used	
	1	Not Used	
	2	Not Used	
	3	Not Used	
	4	Bits 4-7 control whether ports A-F act in synchronous or asynchronous mode. Bits 4-7 enable synchronous mode for the port specified and all lower order ports while higher ports are set to asynchronous mode (i.e. 0x0 = all ports asynchronous, 0x6 = all ports synchronous, 0x3 = ports A-C synchronous)	
	5		
	6		
	7		

Table 3-7, Control Register 3 Functionality of the 1260-114 Module

Register Table		Control Register 3	
Module Version	Bit	Functionality Description	
TTL, CMOS, OC and HVOC	0	0: Disable Interrupts	1: Enable Interrupts
	1	0: Ext. Busy Active Low	1: Ext. Busy Active High
	2	0: Ext. Clock Active + Edge	1: Ext. Clock Active - Edge
	3	0: Reserved	1: Reserved
	4	0: Reserved	1: Reserved
	5	0: Ext. Trigger Not Active (Read Only)	1: Ext. Trigger Active (Read Only)
	6	0: Interrupt Service Required (Read Only)	1: Interrupt Service Not Required (Read Only)
	7	0: Module Is Asserting Interrupt Line (Read Only)	1: Module Is Not Asserting Interrupt Line (Read Only)

Table 3-8, EPROM Descriptor Functionality of the 1260-114 Module

Register Table		EPROM Descriptor Register
Module Version	Bit	Functionality Description
TTL, CMOS, OC and HVOC	0	This register each time read advances a memory pointer to the next memory location in an EPROM. To reset this pointer to the beginning, simply read the ID register and the memory pointer resets to zero. The descriptor register contains a long string of data, typically used by the Adapt-a-Switch carrier for configuration purposes. Additionally, this data has the card identification string for the specific type of card (i.e. 1260-114TTL or 1260-114CMOS). These identification strings are located at EPROM memory locations 0x23-0x34
	1	
	2	
	3	
	4	
	5	
	6	
	7	

Writing to a port location is a straightforward process. Setting a bit high in a port register causes the port to output a high logic level on the port pin corresponding to that bit. In the case of an open-collector version, this same operation would cause the pull-down transistor to activate.

It is especially important to realize that a single write operation controls eight separate control lines or output devices simultaneously. Therefore if only a single bit change is desired, the following process must be observed.

1. Read the register first, inverting the bit pattern if necessary
2. Mask the appropriate bit with an 'AND' operation and a byte mask with all undesired bits set to a '1' and the desired bit set to a '0' or '1' depending on whether the bit is to be set or cleared in the desired register
3. Write the masked data back into the register

As simple as this may seem, a number of products reported as faulty and sent back for repair are nothing more than the result of inappropriate register accesses.

Reading a 1260-114 register has a few details that must also be considered. Depending on what version of the 1260-114 is used, some registers when read, provide data that is inverted from that written to the register in an earlier operation. **Tables 3-1 through 3-8** indicate whether bit inversion occurs for a particular register and whether it occurs in all versions of the 1260-114 or for only select versions.

The VISA I/O library may be used to control the module. The VISA function `viOut8()` is used to write a single 8-bit byte to a control register, while `viIn8()` is used to read a single 8-bit byte from the control register. The following code example shows the use of `viOut8()` to update the 1260-114 module.

1260-114 Example Code

```
#include <visa.h>

/* This example shows a 1260-01T at logical address 16 and a VXI/MXI */
/* interface */
#define RI1260_01_DESC      "VXI::16"

/* For a GPIB-VXI interface, and a logical address of 77 */
/* the descriptor would be: "GPIB-VXI::77" */

/* this example shows a 1260-114 with module address 7, port 1,
and write data of 0xAA */
#define MOD_ADDR_114      7
#define PORT_NUMBER      1
#define DATA_ITEM        0xAA

void example_operate_1260_114(void)
{
    ViUInt8 creg_val;
    ViBusAddress portA_addr, offset;
    ViSession hdl1260;      /* VISA handle to the 1260-01T */
    ViSession hdlRM;       /* VISA handle to the resource manager */
    ViStatus error;        /* VISA error code */

    /* open the resource manager */
    /* this must be done once in application program */
    error = viOpenDefaultRM (&hdlRM);

    if (error < 0) {
        /* error handling code goes here */
    }

    /* get a handle for the 1260-01T */
    error = viOpen (hdlRM, RI1260_01_DESC, VI_NULL,VI_NULL, &hdl1260);
    if (error < 0) {
        /* error handling code goes here */
    }

    /* form the offset for control register 0 */
    /* note that the base A24 Address for the 1260-01T */

```

```
/* is already accounted for by VISA calls viIn8() and */
/* viOut8() */

/* module address shifted 10 places = module address x 1024 */
portA_addr = (MOD_ADDR_114 << 10) + 1;
offset = portA_addr + (PORT_NUMBER << 1);

error = viOut8 (vi, VI_A24_SPACE, offset, DATA_ITEM);

if (error < 0)

    return( error );

/* close the VISA session */
error = viClose( hdl1260 );
if (error < 0) {
    /* error handling code goes here */
}
}
```

This page was left intentionally blank.

Chapter 4

OPTIONAL ASSEMBLIES

407664	Connector Kit, 160 Pin Crimp	6-3
407408-001	Cable Assy, 160 Pin, 6 ft, 24AWG.....	6-4

This page was left intentionally blank.

RACAL INSTRUMENTS, INC.

Assembly 407664

Connector kit, 160 Pin, Crimp Rev Date 7/30/98 Revision A

#	Component	Description	U/M	Qty Reqd.	REF
1	602258-116	CON-CAB-RCP160C,100S	-E EA	1.000	
2	602258-900	TRMCRP-SNP-U-F26-20G	-E EA	170.000	

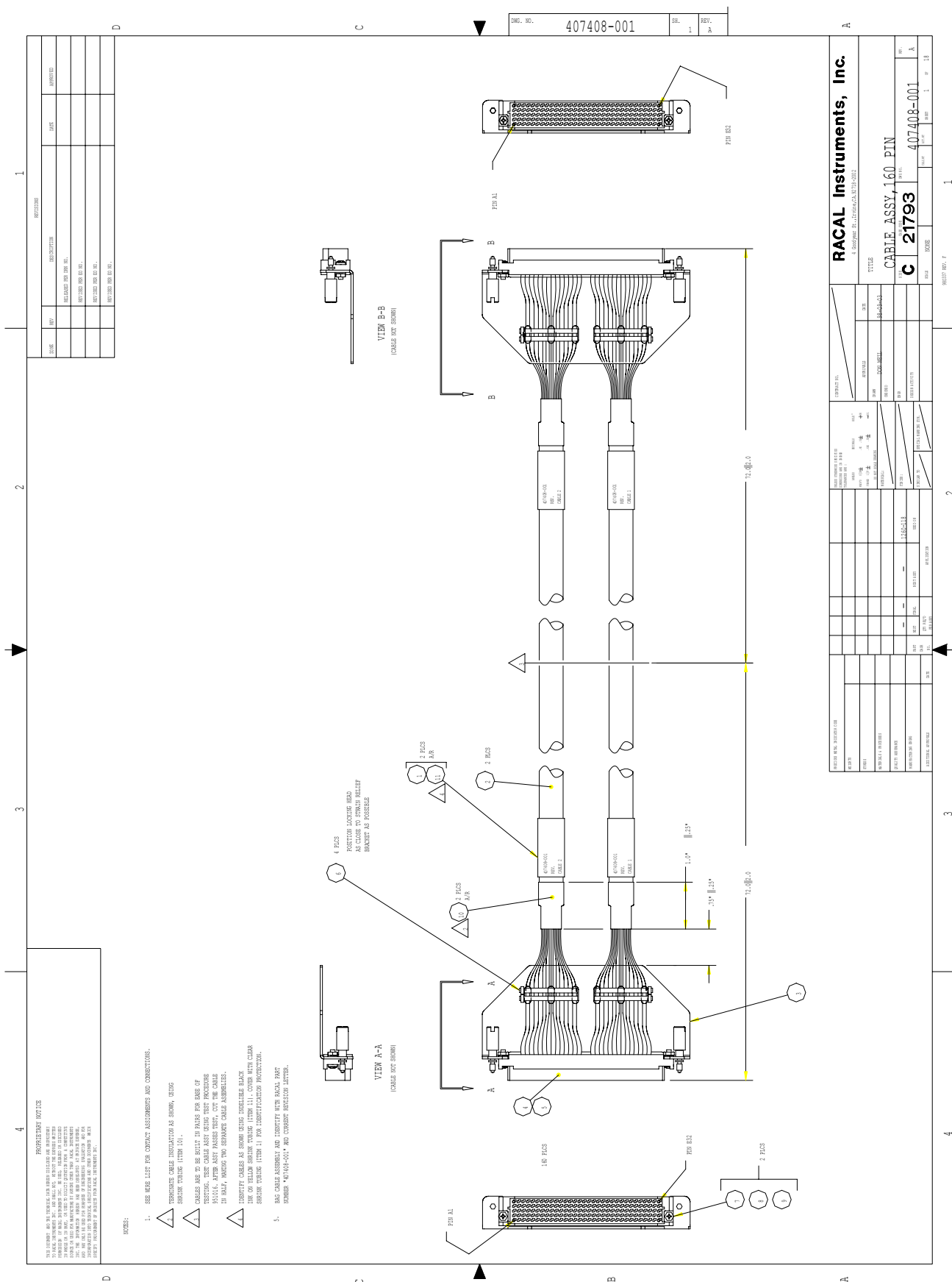

REV	DESCRIPTION	DATE	APPROVED

DRG. NO.	407408-001	REV.	1
REV.	1	DATE	

RACAL Instruments, Inc.
 A COMPANY OF INTERNATIONAL ELECTRONICS

ITEM NO. 407408-001
 TITLE
CABLE ASSY, 160 PIN

REV. **C 21793**

DATE 1 8 98

PROCESSED NOTES

THE CUSTOMER HAS NOT IDENTIFIED ANY OTHER CALLOUTS OR IDENTIFIERS FOR THIS DRAWING. THE CUSTOMER HAS NOT IDENTIFIED ANY OTHER IDENTIFIERS OR IDENTIFIERS FOR THIS DRAWING. THE CUSTOMER HAS NOT IDENTIFIED ANY OTHER IDENTIFIERS OR IDENTIFIERS FOR THIS DRAWING.

- NOTES:
- SEE WIRE LIST FOR CONTACT ASSIGNMENTS AND CONNECTIONS.
 - TERMINATE CABLE INSULATION AS SHOWN, USING SHRINK TUBING (ITEM 11).
 - COVER AND OR THE WIRE TO THE END OF THE CABLE AS SHOWN IN THE WIRE LIST. AFTER THE LAST PINS HAVE BEEN TESTED, CUT THE CABLE TO HALF, MAKING TWO SEPARATE CABLE ASSEMBLIES.
 - IDENTIFY CABLES AS SHOWN USING IDENTIFIABLE BLACK TIE OR YELLOW SHRINK TUBING (ITEM 11), COVER WITH CLEAR SHRINK TUBING (ITEM 11) FOR IDENTIFICATION PROTECTION.
 - RACAL CABLE ASSEMBLY AND IDENTIFY WITH BLACK PAINT NUMBER "407408-001" AND CONTACT IDENTIFICATION LETTER.

Chapter 5

PRODUCT SUPPORT

Product Support

EADS North America Defense Test and Services, Inc. has a complete Service and Parts Department. If you need technical assistance or should it be necessary to return your product for repair or calibration, call 1-800-722-3262. If parts are required to repair the product at your facility, call 1-949-859-8999 and ask for the Parts Department.

When sending your instrument in for repair, complete the form in the back of this manual.

For worldwide support and the office closest to your facility, refer to the website for the most complete information <http://www.eads-nadefense.com>.

Warranty

Use the original packing material when returning the 1260-114 to EADS North America Defense Test and Services, Inc. for calibration or servicing. The original shipping container and associated packaging material will provide the necessary protection for safe reshipment.

If the original packing material is unavailable, contact EADS North America Defense Test and Services, Inc. Customer Service at 1-800-722-3262 for information.

REPAIR AND CALIBRATION REQUEST FORM

To allow us to better understand your repair requests, we suggest you use the following outline when calling and include a copy with your instrument to be sent to the EADS North America Defense Test and Service, Inc. Repair Facility.

Model _____ Serial No. _____ Date _____

Company Name _____ Purchase Order # _____

Billing Address _____

City

State/Province

Zip/Postal Code

Country

Shipping Address _____

City

State/Province

Zip/Postal Code

Country

Technical Contact _____ Phone Number () _____

Purchasing Contact _____ Phone Number () _____

1. Describe, in detail, the problem and symptoms you are having. Please include all set up details, such as input/output levels, frequencies, waveform details, etc.

2. If problem is occurring when unit is in remote, please list the program strings used and the controller type.

3. Please give any additional information you feel would be beneficial in facilitating a faster repair time (i.e., modifications, etc.)

4. Is calibration data required? Yes No (please circle one)

Call before shipping
Note: We do not accept
"collect" shipments.

Ship instruments to nearest support office.